

Jarosław PSZCZOŁA¹
Tomasz CETNAR²

MEASUREMENTS OF HUGE MAGNETOSTRICTION OF THE HEAVY RARE EARTH – IRON INTERMETALLICS

The method described in this work is the strain gauge method used to measure huge magnetostriction of the heavy rare earth – iron intermetallics. The measuring system and the procedure of measurement are presented in this work. The results of huge magnetostriction determined for the heavy rare earth-iron compounds with the MgCu₂ – type crystal structure are shown.

Keywords: strain, huge magnetostriction, measuring system, heavy rare earth, iron, intermetallics

1. INTRODUCTION

Magnetostriction, discovered by James Joule in nickel in 1842, involves changing the dimensions and the shape of the material under the influence of magnetic field [1]. Linear magnetostriction, recognized as equivalent to linear strain is defined as $\Delta l/l = \lambda$, where Δl is the change of the length l induced by the applied external magnetic field characterized by field intensity H [2-4]. The theory of magnetostriction can be found in literature as, for example, in [4-6]. Internal forces which induce magnetostriction are of quantum-mechanical nature.

The $\Delta l/l$ quotient labelled as $\lambda(H)$ changes with the increased field strength H . For large values, H reaches its saturation level λ_s . A change of the strain is associated with the rotation of the domains accompanying the growing H . The λ_s parameter equals -7×10^{-6} (-7 ppm) for iron, -60 ppm for cobalt and -35 ppm for nickel [7]. The values of magnetostriction observed for the 3d transition metals (*Fe, Co, Ni*) are too small to be used in applications.

There are, however, other intermetallic materials with big or large magnetostriction, which have various applications, for instance as sensors or actuators

¹ Department of Experimental Physics, Faculty of Mathematics and Applied Physics, Rzeszów University of Technology, Al. Powstańców Warszawy 6, 35-959 Rzeszów, e-mail: j.pszczola@prz.edu.pl (J. Pszczoła)

² AGH, Kraków, Polska

[6,8]. For this reason, the significance of heavy rare earth – iron (RFe_2) compounds is dominant. These materials have a number of advantages, namely: short reaction time, low power consumption, operability in difficult working conditions, ability to withstand heavy load, and are subject to a relatively simple synthesis, as discussed in literature [9].

Both scientific and practical reasons create interest in various studies of these materials. Especially, measurements of their magnetostrictions are of vital importance. Different experimental methods can be used to measure linear magnetostriction, for instance: dilatometer technique, interferometry measurements, capacitance method, X-ray studies and the strain gauge method. The strain gauge tensometry is a simple and cost-saving method to measure the strain of a material as a result of the intensity of the applied external magnetic field.

The purpose of the paper is to describe the basic strain gauge apparatus for magnetostriction measurements, the measurement procedure, as well as the exemplary results obtained for huge magnetostrictive materials.

2. THE STRAIN TENSOMETRY

Stress and strain

Stress σ is the relation of the applied force F to the area S where it acts [10]. In accordance with Fig. 1, results can be expressed as

$$\sigma = F/S = F/(x-\Delta x)(y-\Delta y) \quad (1)$$

Acting force F induces the longitudinal strain ε , defined by the relation

$$\varepsilon = \Delta z / z \quad (2)$$

The stress σ and the strain ε are related with Hooke's law, namely

$$\varepsilon = \sigma/E \quad (3)$$

where E is the Young's modulus.

Longitudinal strain ε is accompanied by a transverse constriction η defined by the ratio (Fig. 1)

$$\eta = \Delta x/x \quad (4)$$

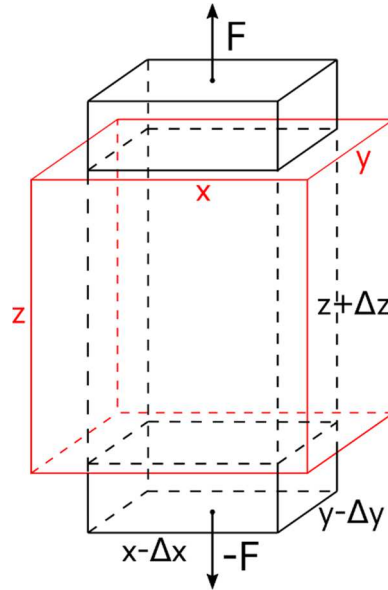

Fig. 1. Stress and strain of the cuboid specimen as a result of the acting force F ; the cuboid (red contour) before acting of the F force, the cuboid (black contour) as a result of the acting force

Electrical resistance and strain

Electrical resistance R of a wire is described by a simple formula [10]

$$R = \rho l / A \quad (5)$$

where ρ is the proper resistance of the wire material, l is the length of the wire and A is its cross sectional area.

If the stress is applied to the wire, its length l increases by Δl , its cross sectional area A decreases, and consequently its resistance R increases by ΔR . Thus, sensitivity κ for the wire can be defined with the use of the expression [10]

$$\kappa = (\Delta R / R) / (\Delta l / l) = (\Delta R / R) / \varepsilon \quad (6)$$

Assuming that the κ parameter is constant, it can be seen from the last formula that the electrical resistance ΔR varies in proportion to the strain ε . The last formula constitutes the basis for the operation of a strain gauge [10].

Strain gauge

As mentioned above, the most popular and simple method to determine strain is to use a strain gauge. In order to reduce strain gauge size and to increase its efficiency, its main component, i.e. a thin resistive wire is aligned as a grid

(Fig. 2, left-hand side). Thin wires of copper-nickel alloy (constantan) or nickel-chromium alloy are commonly used. The grid is located on a thin carrier and fixed to it by a thin layer. The grid is finished with solder pads allowing the connection with Wheatstone bridge. The active gauge is tightly glued to the tested specimen by a thin layer of the cyanoacrylate adhesive (Fig. 2, right-hand side) [11, 12].

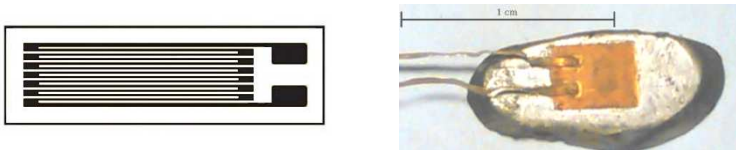

Fig. 2. Longitudinal strain gauge. Ohmic wire grid (left), a sample with the glued strain gauge (right)

The strain gauge element is characterized by its κ and R parameters (formula 6). When a specimen (Fig. 1) is strained along the Z axis, the strain is transmitted through the adhesive to the grid resistor changing its electrical resistance. The tensometric amplifier electrically stimulates Wheatstone bridge (Fig. 3) providing an input voltage U_{in} [11]. The change in electrical resistance of the active gauge glued to the grid change the output voltage U_{out} . The amplifier circuit records this voltage and microprocessor calculates the value ΔR and as a result determines the strain ε (formula 6). In the case when the gauge is glued along the X axis, the amplifier circuit records the transverse strain η .

Wheatstone bridge

Figure 3 shows schematic arrangements and the photography of Wheatstone bridge. A sample with the glued strain gauge and three accompanying strain gauges are mounted on a thin laminate plate.

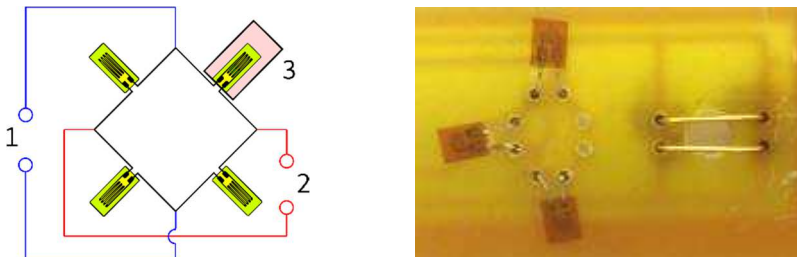

Fig. 3. Wheatstone bridge diagram consisting of four strain gauges (left), 1 - input U_{in} voltage, 2 - output U_{out} voltage, 3 - specimen under measurement with the glued strain gauge. Photo (right) of Wheatstone bridge consisting of strain gauges glued to a thin carrier plate

3. THE MAGNETOSTRICTION MEASURING SYSTEM

The measuring system (a diagram presented in Fig. 4) consists of: 1 – specimen of a magnetostrictive material (with a Wheatstone bridge) located centrally between the pole pieces of the electromagnet using the $XYZ;\theta$ positioning system, 2 – the tensometric amplifier, 3 – Hall probe system (the probe and the meter), Hall probe is positioned close to the tested specimen, 4 – PC computer, 5 – multimeter, 6 – power supply for electromagnet, 7 – electromagnet.

The photograph (Fig. 5) shows main components of the measuring system.

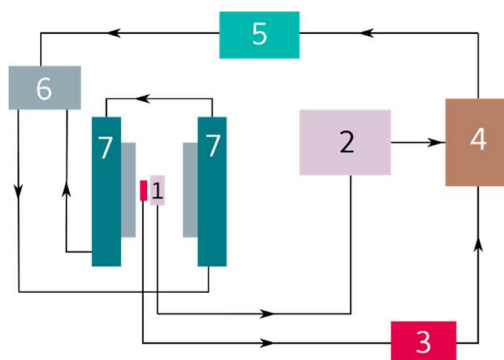

Fig. 4. A diagram of magnetostriction measuring system:
 1 – specimen with Wheatstone bridge, 2 – tensometric amplifier,
 3 – Hall probe system, 4 – PC, 5 – multimeter, 6 – power supply,
 7 – electromagnet with pole pieces

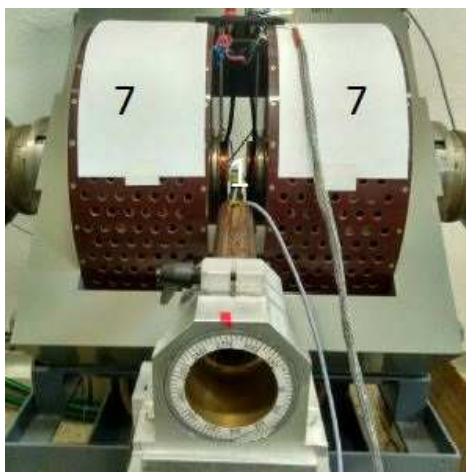

Fig. 5. Photo of the main part of the measuring system:
 1 – the specimen with the attended Wheatstone bridge,
 7 – 7 – the electromagnet with the pole pieces

The process of measuring. As a result of a command sent from the computer (4), a power supply (6) slowly increases the direct current running via the coils of the electromagnet (7), thus increasing the magnetic field intensity.

H from zero to the requested H_{max} , and the magnetic field induces the strain in the specimen. The direct current is controlled by the computer (4) using the multimeter (5). Consequently, the increasing $\varepsilon(H)$ strain is measured by the tensometer measuring set (2) (a Wheatstone bridge and the tensometric amplifier) and the result is recorded by the computer (4). Both the Hall probe (3) and the computer (4) control the magnetic field intensity H .

The determined strain ε equals to the λ magnetostriction parameter.

Measurement of the longitudinal magnetostriction λ_{\parallel}

Figure 6 shows the geometry of the measurement of the longitudinal magnetostriction λ_{\parallel} .

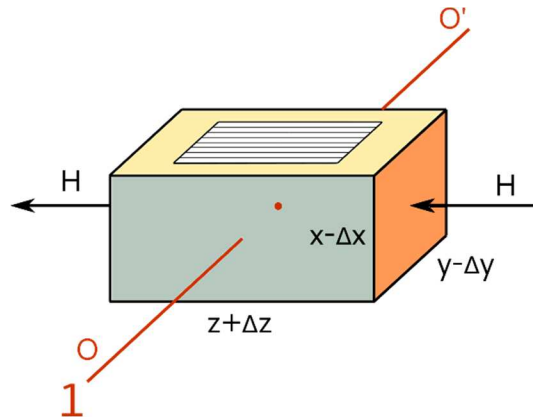

Fig. 6. The geometry of the measurement of the longitudinal magnetostriction λ_{\parallel} . The magnetic field intensity is perpendicular to the (x,y) wall surface. The strain gauge is glued to the specimen along the z -direction. It measures the strain in the z -direction

The axis of rotation OO' is in the position 1, the z dimension is parallel to the magnetic field intensity H . As a result of the magnetic field influence, the specimen is elongated to $z+\Delta z$, the strain gauge records the ε strain. Perpendicularly to the field H the specimen is reduced to $x-\Delta x$ and $y-\Delta y$ dimensions. The longitudinal magnetostriction λ_{\parallel} equals

$$\varepsilon = \Delta z/z = \lambda_{\parallel} \quad (7)$$

In accordance with Figures 1 and 6.

The measurement of transverse magnetostriction λ_{\perp}

Figure 7 shows the geometry of the measurement of transverse magnetostriction λ_{\perp} . The OO' axis is in the position 2, it is rotated clockwise by 0.5π . In this case, the x dimension is parallel to the magnetic field intensity H .

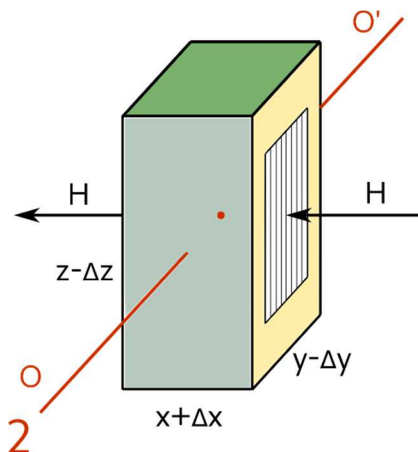

Fig. 7. The geometry of the measurement of transversal magnetostriction λ_{\perp} .
 The magnetic field intensity is perpendicular to the (y,z) wall surface.
 The strain gauge is glued to the specimen along the z -direction.
 It measures the shortening along the z -direction

As a result of the magnetic field influence, the specimen is elongated to $x+\Delta x$ introducing the ε strain. Perpendicularly to the field H , the specimen is reduced to $z-\Delta z$ and $y-\Delta y$ dimensions. In that case, the gauge measures the constriction in the z -direction,

$$\eta = \Delta z/z = \lambda_{\perp} \quad (8)$$

i.e., it measures the strain η or the transversal magnetostriction λ_{\perp} .

4. MAGNETOSTRICTION OF THE RARE EARTH – IRON COMPOUNDS

Materials

The strain gauge method was used to measure magnetostriction of the exemplary RFe_2 -type compounds (R – rare earth). The synthesis of these materials has been carried out using the arc melting method with the non-contact ignition, as described in this work [9]. On the basis of X-ray studies carried out it is known that the RFe_2 intermetallics form a regular flat centred Laves phase $Fd\bar{3}m$, $C15$,

$MgCu_2$ – type structure. The $C15$ Laves phase has been described in detail in other works [13].

Magnetostrictions

Fig. 8 shows the results of magnetostriction measurements for the polycrystalline $TbFe_2$ (curve 1), $Tb_{0.27}Dy_{0.73}Fe_2$ (2) and YFe_2 (3) compounds. For $TbFe_2$ and $Tb_{0.27}Dy_{0.73}Fe_2$ the longitudinal λ_{\parallel} and the transverse λ_{\perp} magnetostrictions reach huge values. Since the $TbFe_2$ compound has a large magnetocrystalline anisotropy, its magnetostriction parameters increase with the growing intensity of the magnetic field, yet they do not tend to saturate. This property poses problems in applications. The mixture $R=Tb_{0.27}Dy_{0.73}$ in the $Tb_{0.27}Dy_{0.73}Fe_2$ compound known as Terfenol D removes this difficulty [6]. Magnetostrictions are reduced as compared to the $TbFe_2$ values, yet are still huge and tend to saturate with the growing intensity of the external magnetic field (curve 2). For this rare earth composition the magnetocrystalline anisotropy is reduced to almost zero [6,8]. Huge magnetostrictions have their origins in large magnetic moments of $4f$ -atomic shells of rare earths. These moments, influenced by the external magnetic field, interact with the crystal lattice introducing the strain or the magnetostriction of this lattice [4,6].

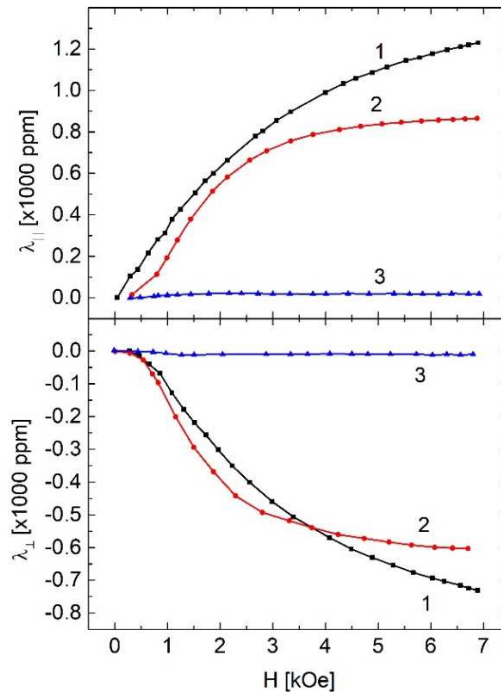

Fig.8 The longitudinal λ_{\parallel} and transversal λ_{\perp} magnetostriction parameters measured against the intensity H of the external magnetic field for compounds: 1 – $TbFe_2$, 2 – $Tb_{0.27}Dy_{0.73}Fe_2$ and 3 – YFe_2 .

It is worth noting that the theoretical magnetic moment $gJ\mu_B$ of *Tb* equals to $9\mu_B$ (experimental value 9.34) and that of *Dy* equals to $10\mu_B$ (experimental value 10.33) [14]. The letter g indicates the Landé factor and J denotes the number of the total angular quantum momentum of the atomic *4f*-shell, μ_B is the Bohr magneton [3,4,14].

Since yttrium atoms are non-magnetic, they have no magnetic moments, therefore magnetostrictions measured for the *YFe₂* compound (dependencies 3) are close to zero. This isostructural material is added for a comparison with huge magnetostriction compounds.

The experimental error of the magnetostriction measurements can be appreciated as being 1-2 percent.

5. SUMMARY

Production technology of the heavy rare earth – iron intermetallics having huge magnetostriction has been fully developed and described in other works [9].

The present paper describes a simple measuring system of a huge magnetostriction. These technological and testing systems can be used to produce materials with a huge magnetostriction for the laboratory purpose or for the limited industrial use. These systems can be developed to increase their technological and testing power.

Acknowledgement Financed partly by Rzeszów University of Technology, grant no. UPB.FE.20.001.

LITERATURE

- [1] Gibbs M.R.J., *Magnetostriction: 150 Years from the Discovery*, Physica Scripta, 1992, Vol. T45, pp. 115-119.
- [2] Bozorth R.M., *Ferromagnetism*, Van Nostrand, Toronto 1951.
- [3] Morrish A.H., *Fizyczne podstawy magnetyzmu*, PWN, Warszawa 1970 (in Polish).
- [4] S.W. Wonsowski S.W., *Magnetizm*, Nauka, Moskwa 1971 (in Russian).
- [5] Callen E., Callen H.B., *Magnetostriction, Forced Magnetostriction, and Anomalous Thermal Expansion in Ferromagnets*, Phys. Rev., 1965, Vol.139, pp. A 445-471.
- [6] Clark A.E., *Magnetostrictive Rare Earth-Fe₂ Compounds*, in: Wohlfarth E.P., Ed. *Ferromagnetic materials*, Vol.1, North-Holland 1980.
- [7] Coey J.M.D., *Magnetism and Magnetic Materials*, Cambridge University Press, New York 2009.
- [8] Engdahl G., *Handbook of Giant Magnetostrictive Materials*, Academic Press, San Diego 2000.
- [9] Onak M., Pszczoła J., *An arc melting system with a non-contact ignition*, Phys. for Economy, 2018, Vol.1, pp.27-41.
- [10] Roliński Z., *Tensometria oporowa. Podstawy teoretyczne i przykłady zastosowań*, WNT, Warszawa 1981 (in Polish).

-
- [11] TENMEX (producer); www.tenmex.pl
- [12] OMEGA; www.omega.com/en-us/resources/strain-microstrain
- [13] Laves F., *Kristallographie der Legierungen*, Naturwissenschaften, 1939, Vol.27, pp. 65-73 (in German).
- [14] Legvold S., *Rare Earth Metals and Alloys*, in: Wohlfarth E.P., Ed. *Ferromagnetic materials*, Vol.1, North-Holland 1980.

DOI: 10.7862/rf.2021.pfe.7

Received: 15.02.2021

Accepted: 23.08.2021